

# SHERCO MY2022 LAUNCH

## ENDURO

ENDURO RACING  
ENDURO FACTORY  
ENGINE  
125 SE  
250-300 SE  
250-300 SEF  
450-500 SEF

## TRIAL

TRIAL FACTORY  
ENGINE  
125 ST  
250-300 ST

→ SHERCO MY2022 LAUNCH/ ENDURO



# SHERCO MY2022 LAUNCH ENDURO - TRIAL



WATCH THE  
ACTION VIDEO

**SHERCO**

# ENDURO RACING



250 SE

300 SE

300 SEF



- **NEW** 2022 GRAPHICS KIT
- BLACK COMFORT SEAT
- BLACK FRAME GUARDS
- **NEW** HANDLEBAR GRIPS
- **NEW** KAYABA OPEN CARTRIDGE FORK
- **NEW** KAYABA SHOCK ABSORBER
- BLACK EXCEL RIMS
- MICHELIN MEDIUM ENDURO TIRES
- **NEW** BREMBO BRAKE PADS



## **NEW** 2022 GRAPHICS KIT

The new graphics kit is made with InMold technology, the graphics design is injected directly into the plastic mold. They are durable and more resistant to abrasions.

The Sherco ENDURO range returns to its original blue color.



## BLACK COMFORT SEAT

RACING models are fitted with a black seat for a more discreet look, the cover material is less abrasive than the material used on our FACTORY models.



## BLACK FRAME GUARDS

The 2022, ENDURO range features a sleek design that incorporates shades of gray, that offer excellent frame protection.



## **NEW** HANDLEBAR GRIPS

The grip design has been revised to provide the optimal amount of comfort for our riders.



## **NEW** KAYABA OPEN CARTRIDGE FORK

The 2022 Racing models now also receive KYB suspension units specifically developed for the Racing model. The fork is an open cartridge KYB with soft settings that combine comfort and safety on the bike.

To identify the KYB with open cartridges and KYB with closed cartridges, observe the color of the KYB stickers on the fork. Black for Racing, Red for Factory.



## **NEW** KAYABA SHOCK ABSORBER

Without compromising on quality, the Racing version incorporates the same high-end KYB shock absorber as the FACTORY version.



## BLACK EXCEL RIMS

## MICHELIN MEDIUM ENDURO TIRES

MICHELIN MEDIUM ENDURO tires are fitted to our entire range. (in size 140 at the rear).



## **NEW** BREMBO BRAKE PADS

The ENDURO SHERCO range received new BREMBO brake pads for improved grip and a more progressive engagement.

# WHO IS THE RACING RANGE INTENDED FOR?

The **RACING** range is designed for the rider who likes to spend time on their bike and wants a more comfortable experience. From a Sunday saunter to riding more demanding trails.

The Racing model will allow the rider to perform well in all situations. The rider will find reliability, trust, and performance in the bike.





# ENDURO FACTORY



<b>125 SE</b>
<b>250 SE</b>
<b>300 SE</b>
<b>250 SEF</b>
<b>300 SEF</b>
<b>450 SEF</b>
<b>500 SEF</b>



- **NEW** 2022 GRAPHICS
- **NEW** DIAMOND PATTERN GRAY SELLE DALLA VALLE SEAT
- KAYABA CLOSED CARTRIDGE SUSPENSION UNITS
- AKRAPOVIC / **NEW** SHERCO FACTORY 4T EXHAUST
- AXP SKID PLATE
- GALFER BRAKE DISC (FRONT)
- **NEW** LESS CUMBERSOME NEKEN HANDLEBAR PAD
- EXPANSION TANK AND RADIATOR FAN
- **NEW** BREMBO BRAKE PADS



## **NEW** 2022 GRAPHICS

The new graphics kit is made with InMold technology, the graphics design is injected directly into the plastic mold. They are durable and more resistant to abrasions.

The Sherco ENDURO range returns to its original blue color.



## **NEW** DIAMOND PATTERN GRAY SELLE DALLA VALLE SEAT

The Gray SELLE SALLA VALLE seat cover brings its «Factory» design to the motorcycle, it provides increased resistance and non-slip properties for improved performance.

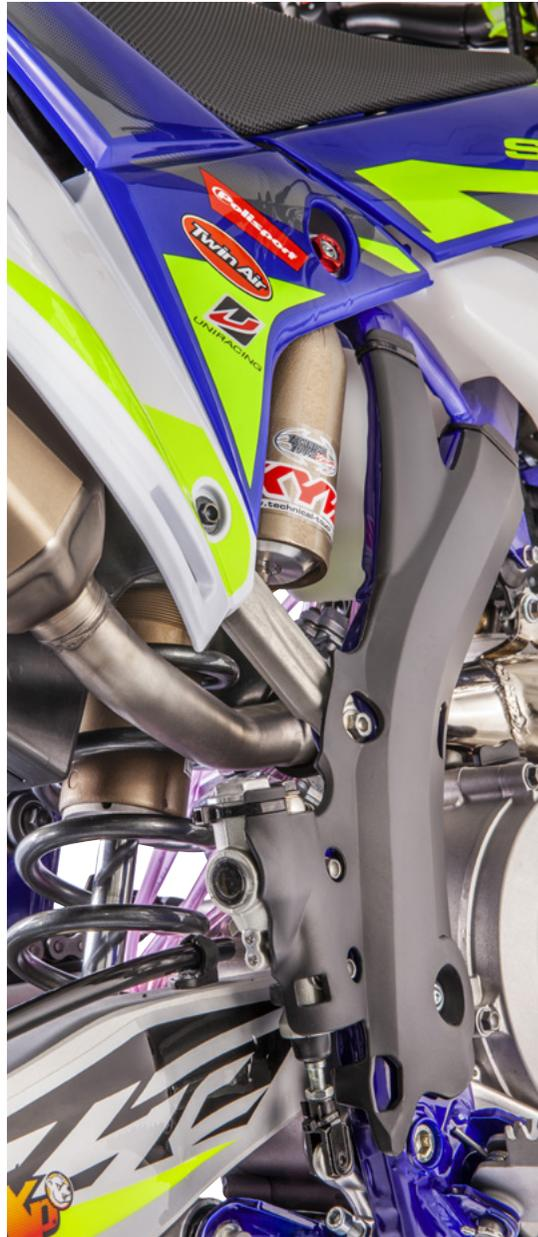

## KAYABA CLOSED CARTRIDGE SUSPENSION UNITS

The KYB shock absorber settings in the Factory range have been reviewed for improved response. A perfect compromise between performance and comfort.

To identify the KYB with open cartridges and KYB with closed cartridges, observe the color of the KYB stickers on the fork. Black for Racing, Red for Factory.



## AKRAPOVIC / **NEW** SHERCO FACTORY 4T EXHAUST

The new exhaust systems provide a significant weight reduction and increased performance along with a real racing appearance.



Titanium



## **AXP SKID PLATE**

Superior quality engine protection that is 6mm thick.

Protecting the motor and the lower parts of the frame that makes the motorcycle ready to ride right from the dealer.



## **GALFER BRAKE DISC (FRONT)**

Because we know you want to apply the brakes at the very last moment, we opted for an ultra-high performing Brembo-Galfer set. The result is better feeling and improved braking power when you apply them.



## **NEW** LESS CUMBERSOME NEKEN HANDLEBAR PAD

The Neken handlebar pad has undergone a complete redesign for a cleaner cockpit. The new design allows the computer to be seen at a glance.



## EXPANSION TANK AND RADIATOR FAN

The expansion tank and radiator fan are standard on our Factory models.

The motorcycle is ready to roll right from the dealer without the need to add any options.



## **NEW** BREMBO BRAKE PADS

The ENDURO SHERCO range received new BREMBO brake pads for improved grip and a more progressive engagement.

# WHO IS THE FACTORY RANGE INTENDED FOR?

The **FACTORY** range is designed for the most demanding riders.

Premium components and factory finishes take the bike to another level. It is the choice of our Sherco Factory Racing Team.

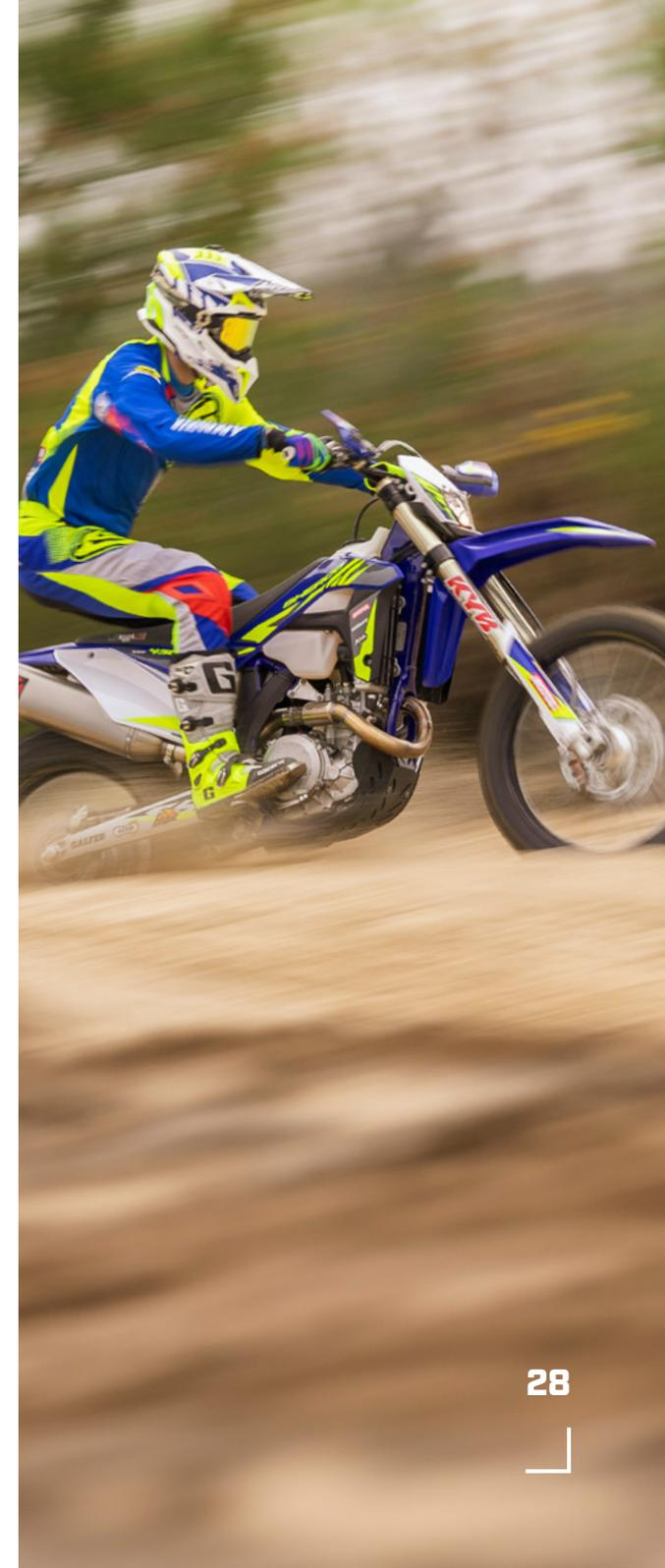

# **ENDURO ENGINES**



**125 SE**



**250-300 SE**



**250-300 SEF**



**450-500 SEF**

# ENDURO 125 SE



AVAILABLE

FACTORY

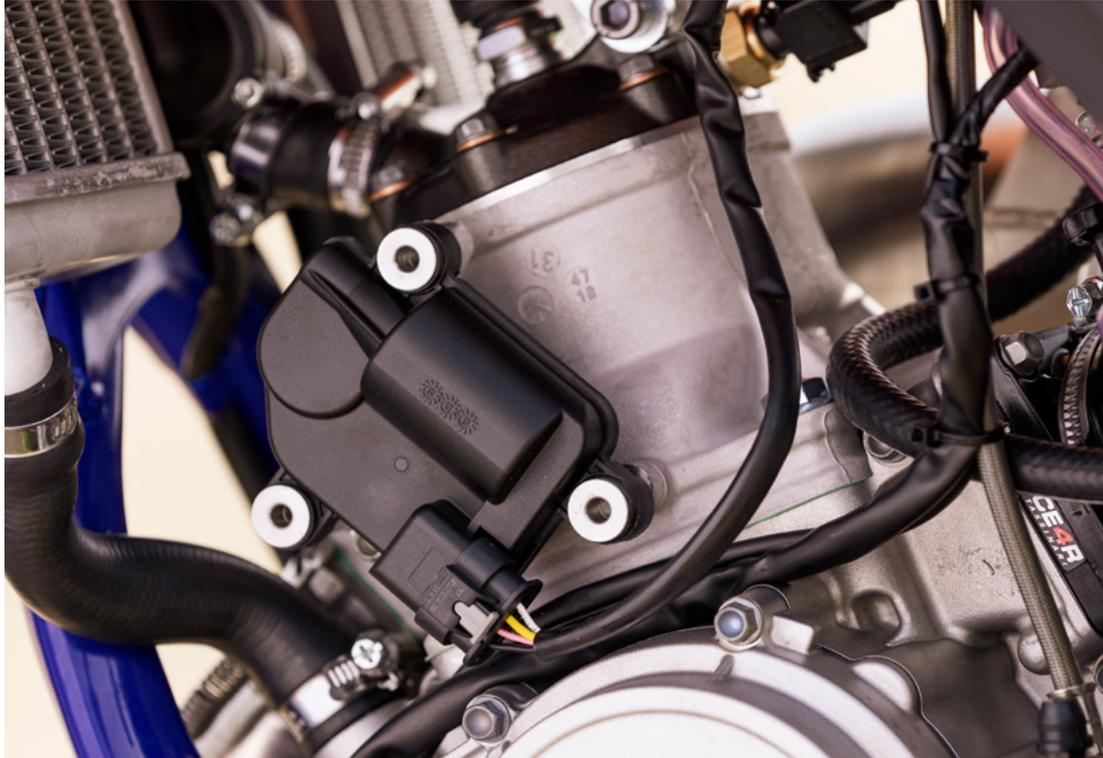

## **NEW** SBS ELECTRONIC EXHAUST SYSTEM

The SBS electronic exhaust valve system allows for a perfect valve opening in every motor situation.

Sherco's engineers have been very innovating and have developed a programmable valve system that allowed our R&D and our test riders to program the perfect valve opening depending on the engine speed and not the throttle opening.

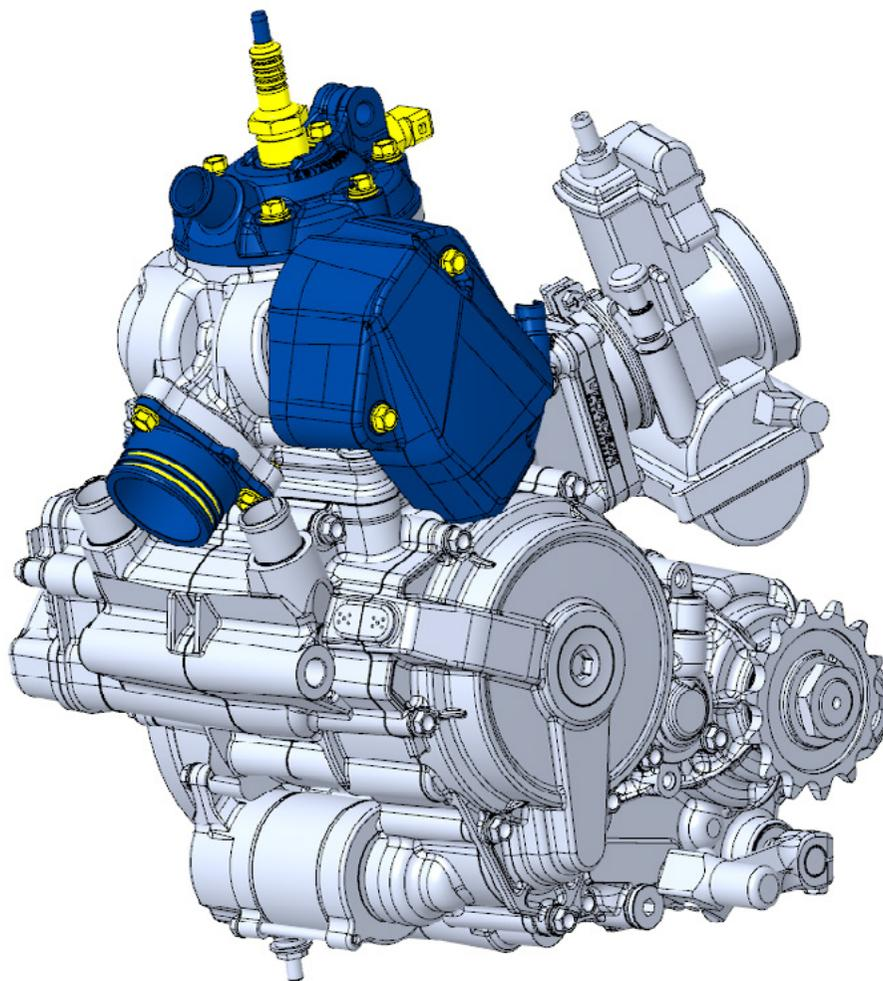

2022 125 SBS

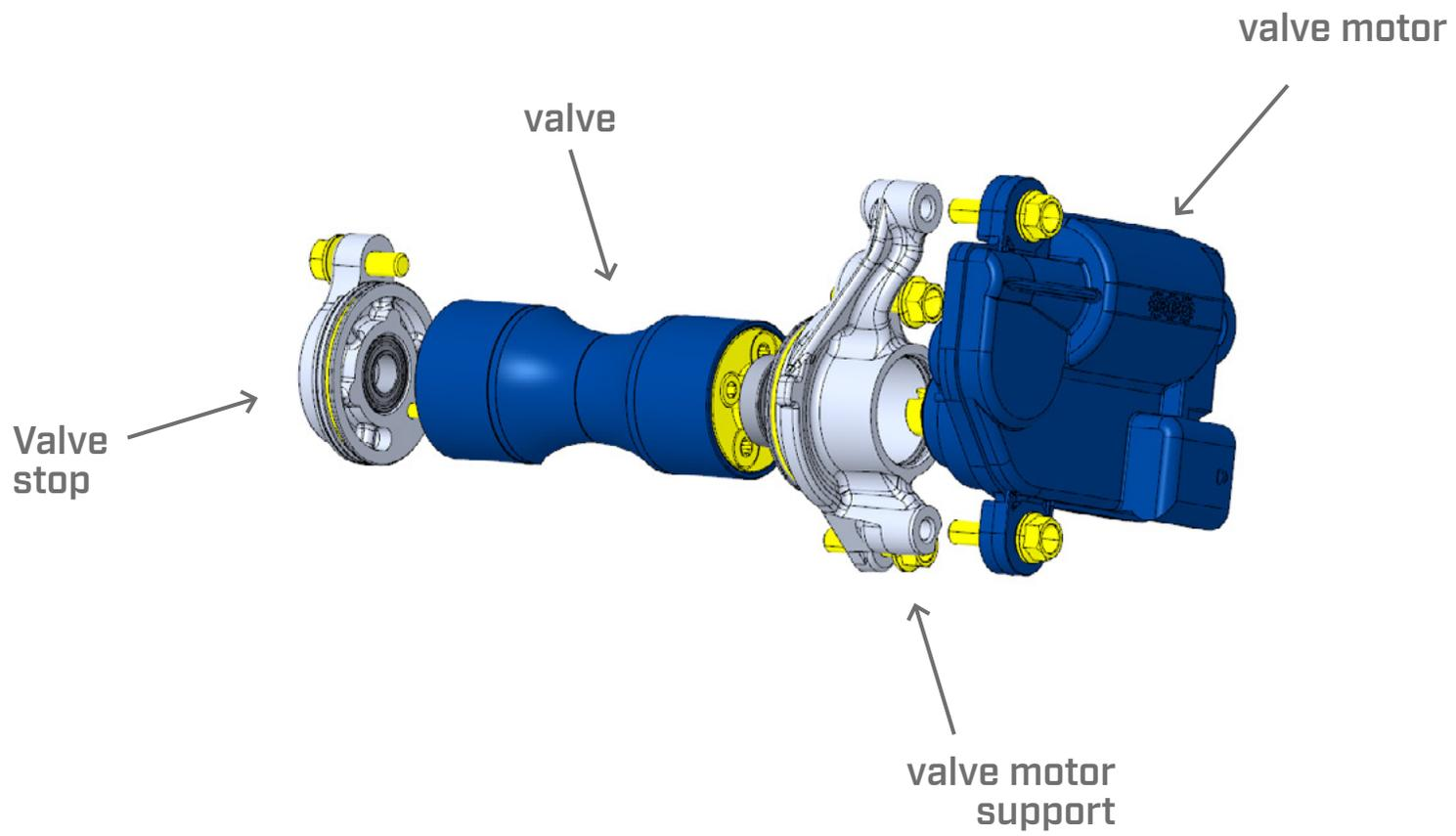

Exploded view of the new valve system.

## WHAT RIDER IS THE 125 SE INTENDED FOR?

The rider that is looking for a lightweight motorcycle that is easy to ride, fun and well equipped. Also, a bike that is comfortable on single track trails as well able to race on more challenging terrain. The SHERCO 125 FACTORY is the perfect partner for performing and progressing in your skill level while offering you maximum pleasure.

Destined for both thrill seekers and seasoned riders, the 125 Sherco is light, compact, powerful, and engaging.



# ENDURO 250-300 SE



AVAILABLE

FACTORY

RACING

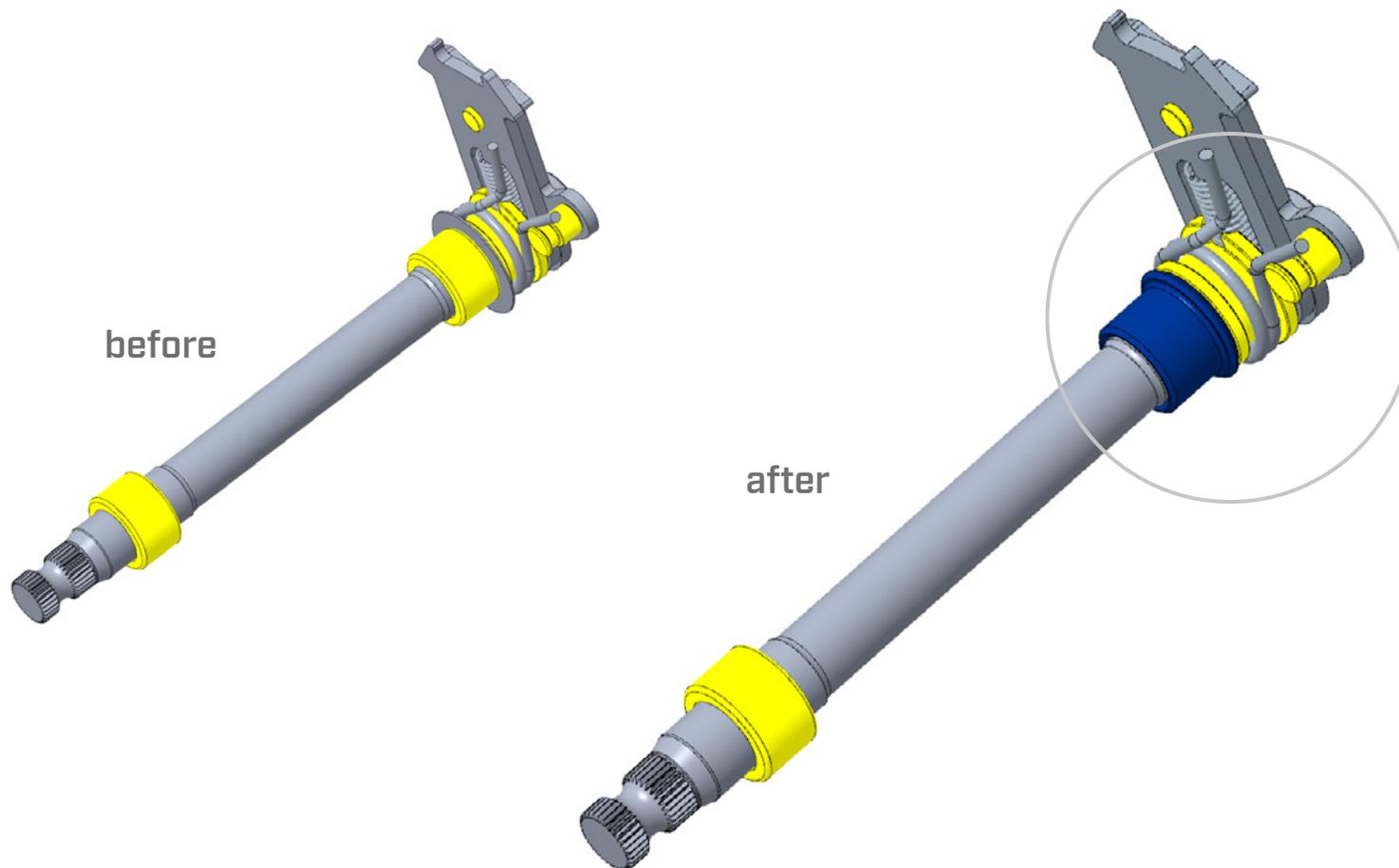

The gear selector has been modified to facilitate its removal in a racing situation.

# WHAT RIDER IS THE 250-300 SE INTENDED FOR?

The rider that is a 2-stroke lover, who wants a bike that can endure unconditional punishment and deliver outstanding power along with the acceleration that only the 2-stroke motor can deliver. Riders who race Extreme races, occasional Enduro racers or performance seekers, these bikes are for you.

The 250 and 300 2-stroke motors have been designed with the main objective of bringing back pure pleasure to the heart of our range. A simple engine to maintain, and one that works in all conditions, from the sea to the mountains, in the mud, the sand or even massive rocks.



# ENDURO 250-300 SEF



AVAILABLE

FACTORY

RACING \*

\* 300 SEF ONLY

# WHAT RIDER IS THE 250-300 SEF INTENDED FOR?

We know that some riders are looking for other feelings, compromises, and versatility. They want a motorcycle that is easy to ride everywhere, one that any rider can adapt to and excel in their chosen environment. The key words that characterize the 250 and 300 SEF are the strong motor, the lightweight, maneuverability and performance.

Whether you are looking to achieve your best time in a special, or just ride for pleasure on any type of terrain or even simply ride for many kilometers, the 250 and 300 SEF will always be your best choice.



# ENDURO 450-500 SEF



AVAILABLE

FACTORY

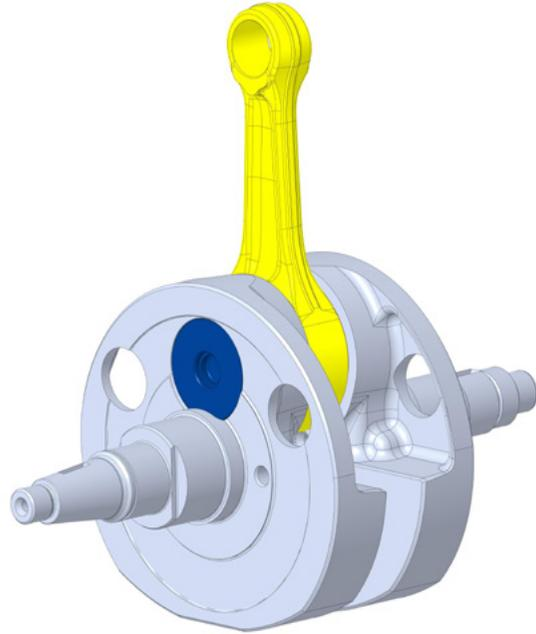

The bottom end of the motor has been reinforced with a new crankshaft and larger bearings.

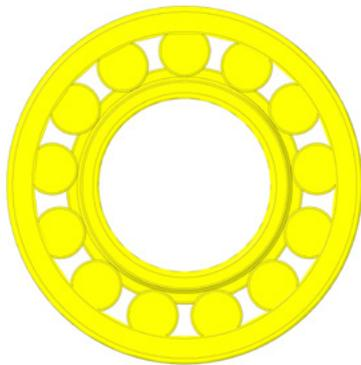

2021  
Ø62 mm

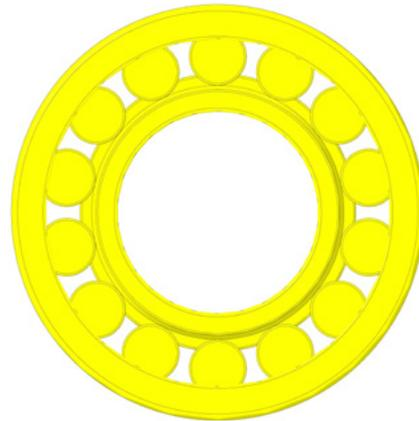

2022  
Ø72 mm

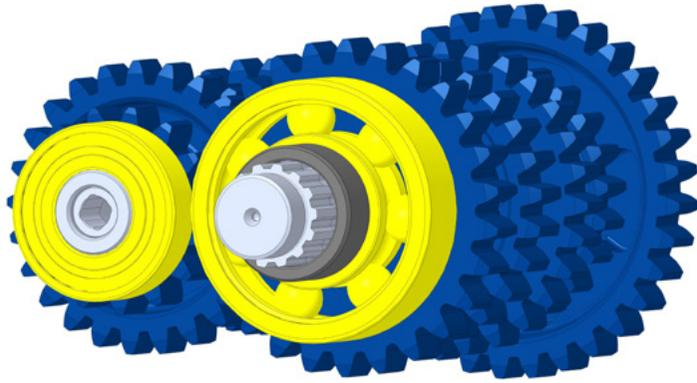

2021

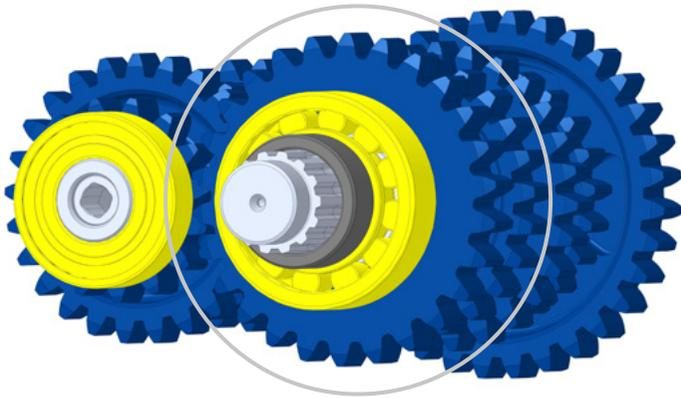

2022

To deliver power to the rear wheel without having any effect on reliability, the gearbox output shaft has received a new larger bearing.



2021

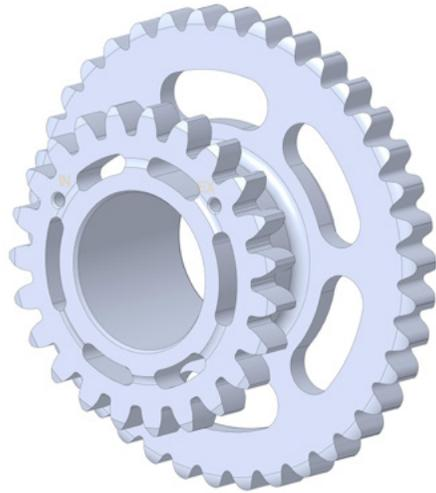

2022

The distribution gear has been lightened.

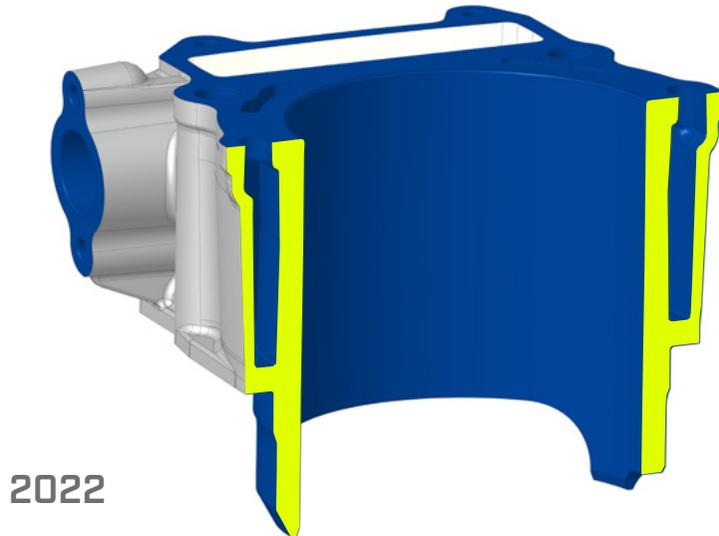
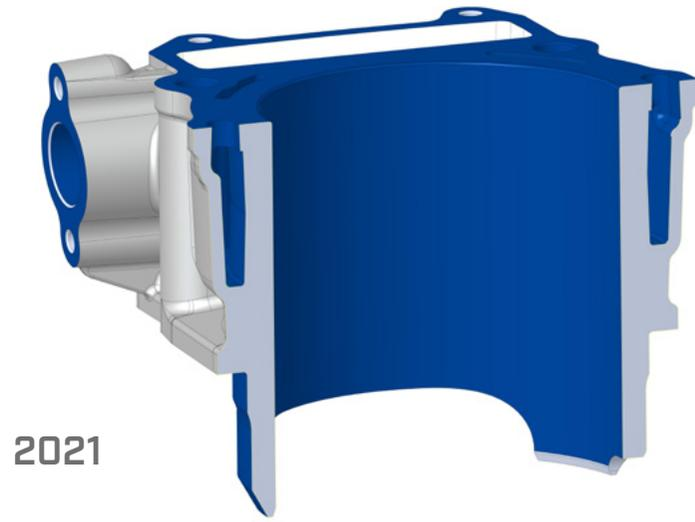

The water jacket in the cylinder block has been increased in capacity to provide better cooling in the most extreme conditions.

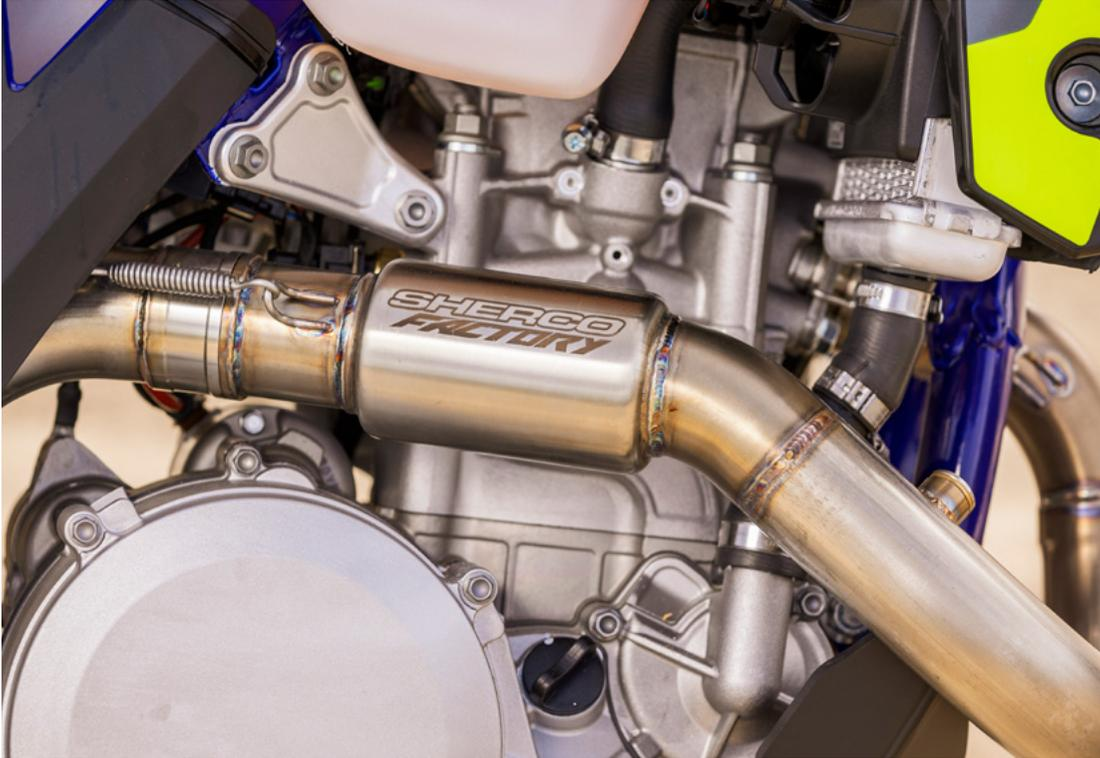

## **SHERCO FACTORY** EXHAUST

The exhaust system and the ignition mapping have been revised for the 2022 model.

These design changes reduce engine braking and allow the engine to rev faster and provide a pleasant power increase that is very linear.

# WHAT RIDER IS THE 450-500 SEF INTENDED FOR?

The rider who rides in the wide-open spaces, the sand and the desert and those racing specialists who look forward to the weekend and want to experience freedom from the mundane. For there is nothing better than a motorcycle that will bring you the exhilarating feeling of power, speed, and stability.





# SHERCO MY2022 LAUNCH

ENDURO - TRIAL



WATCH THE  
ACTION VIDEO

→ SHERCO MY2022 LAUNCH / TRIAL

**SHERCO**

# TRIAL FACTORY





- **NEW** 2022 GRAPHICS
- BLACK WHEELS, YELLOW HUBS, MICHELIN TIRES
- TECH ALUMINUM FORK AND REIGER 2V SHOCK ABSORBER
- **NEW** RED OXIA CYLINDER HEAD
- S3 BLACK HARD ROCK FOOTPEGS
- NEKEN HANDLEBAR PAD
- BRAKTEC MASTER CYLINDER + GALFER BRAKE DISC



## **NEW** 2022 GRAPHICS

The black frame and the new 2022 graphics give a more aggressive look to the range.



**BLACK WHEELS,  
YELLOW HUBS,  
MICHELIN TIRES**



## TECH ALUMINUM FORK AND REIGER 2V SHOCK ABSORBER

Our entire range is equipped with suspensions of the highest quality for the practice of trials: Tech and Reiger.

For the 2022 model, the R&D team developed new settings for the Reiger 2V rear shock absorber to give provide improved response to the motorcycle when traversing big obstacles.



**NEW** RED OXIA CYLINDER HEAD

Oxia cylinder head with interchangeable domes.



## S3 BLACK HARD ROCK FOOTPEGS

The position is adjustable by +/- 2mm



**NEKEN HANDLEBAR PAD**



## **BRAKTEC MASTER CYLINDER + GALFER BRAKE DISC**

The front and rear Galfer brake discs coupled with BRAKTEC master cylinders give the motorcycle safe and powerful brakes.

# WHO IS THE FACTORY RANGE INTENDED FOR?

The **FACTORY ST** range is dedicated to the most demanding riders. Premium components and factory finishes take the bike to another level, it is ready for competition.

It's the choice of our Sherco Factory Team riders. With it you can roll up to the highest step of the podium!



# **TRIAL** **ENGINES**

# TRIAL 125 ST



AVAILABLE

FACTORY

# WHO IS THE 125 ST INTENDED FOR?

It is the perfect bike to get into the world of trials. It is made for those looking for an easy and comfortable trials motorcycle to ride.

Light and responsive, it is the perfect bike to learn on and make safe progress as you develop your skills.



# TRIAL 250-300 ST



AVAILABLE

FACTORY

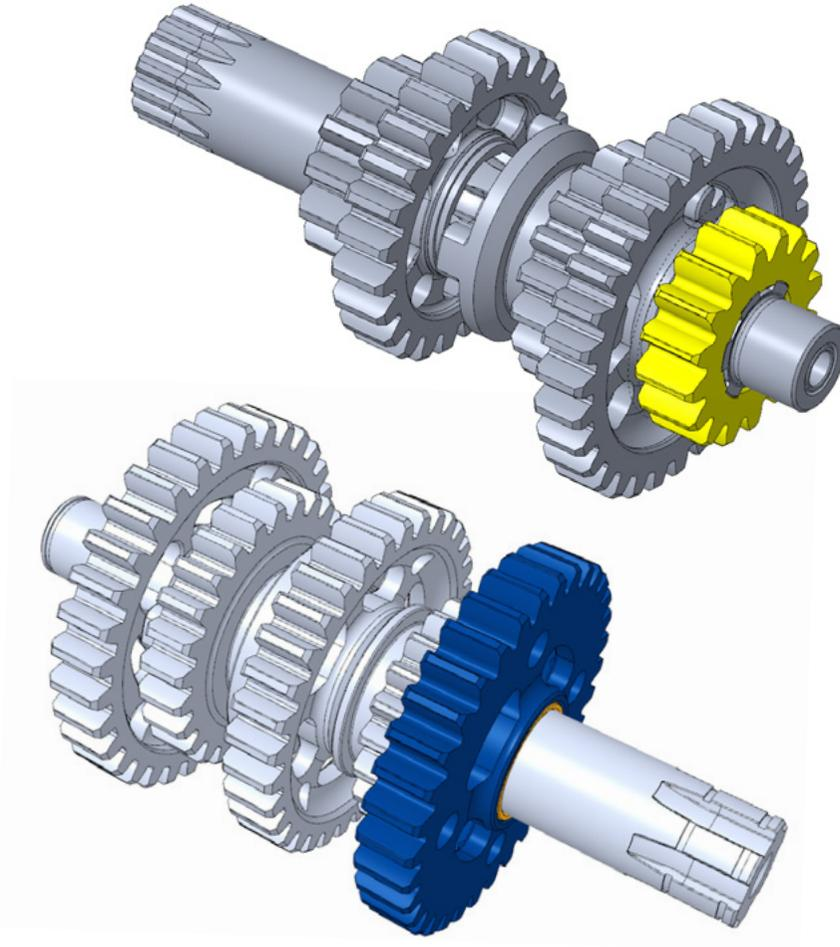

The gearbox has been modified, with a second larger gear that allows riders to attack large obstacles with all the torque they need but also have the speed required to clear the obstacle.



2021

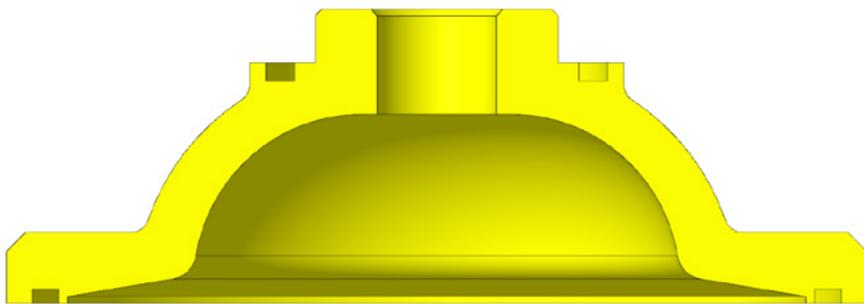

2022  
Increased volume

Our Sherco test riders chose to lower the engine compression to gain progressiveness and flexibility.

## WHO IS THE 250 ST INTENDED FOR?

It is the ideal displacement to move up from a 125 to a higher displacement.

This trial motorcycle is easy to maneuver, it has a smooth motor and it is also very responsive. It enables you to traverse difficult steps and complex sections.

## WHO IS THE 300 ST INTENDED FOR?

The older sister of the range is the most competitive motorcycle in the range. It has been designed and developed to be competitive at the highest level of competition. This displacement has evolved because of the demands of the market. Every component has been carefully thought out and provided to take you to the summit in trials competition.





***SHERCO***